

# ARG 585/A+

12NC: 858600510000

EAN code: 8003437134913



SENSING THE DIFFERENCE

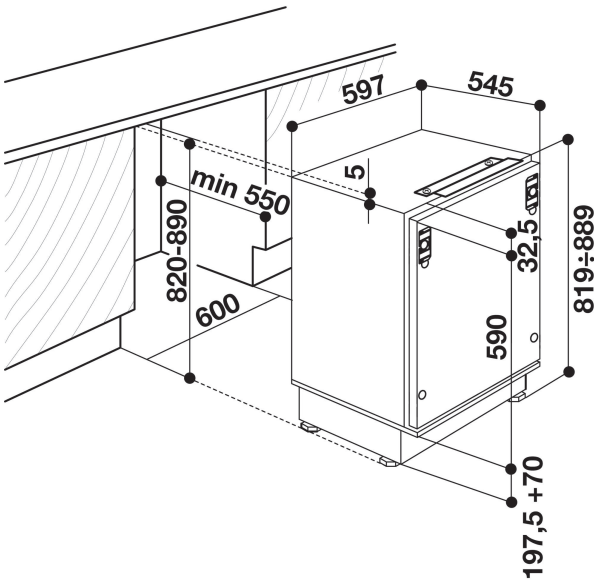

## MAIN FEATURES

Product group	Refrigerator
Commercial code	ARG 585/A+
EAN code	8003437134913
Construction type	Built-in
Installation type	Ugradno-podpultni
Type of control	Mechanical
Type of control setting and signalling devices	Mechanic
Main colour of product	White
Connection rating (W)	100
Current (A)	16
Voltage (V)	220-240
Frequency (Hz)	50
Length of Electrical Supply Cord (cm)	245
Plug type	Schuko
Total unit net capacity (l)	146
Star Rating	Automatic
Number of independent cooling systems	1
Height of the product	815
Width of the product	596
Depth of the product	544
Depth with open door 90 degree (mm)	-
Maximum adjustability feet	0
Net weight (kg)	32
Door hinge	Right reversible

## TECHNICAL FEATURES

-	-
Warning signal / Malfunction	No signal
Defrost process fridge section	Automatic
Fast cooling switch	Ne
Interior ventilator fridge section	Ne
Shelves for Bottles	Ne
Lockable door	Ne
Number of shelves in fridge compartment	4
Number of Adjustable Shelves in fridge compartment	3
Material of the shelves	Glass
Thermometer fridge section	None

## ENERGY LABEL

Energy efficiency class - NEW (2010/30/EC)	A+
Energy consumption annual (kWh/annum) - NEW (2010/30/EC)	120
Refrigerator Net capacity (l) - NEW (2010/30/EC)	146
Freezer Net capacity (l) - NEW (2010/30/EC)	0
Freezing capacity (kg/24h) - NEW (2010/30/EC)	0
Temperature rise time (h)	0
Climate class	N-ST
Noise level (dB(A) re 1 pW)	37
Frost free system	Ne
Maximum ambient temperature	-
Minimum ambient temperature	-
Other Compartment	-